

REV.	DESCRIPTION	DATE	BY	APP.
A	REDRAWN AND REVISED, PUT ON AUTOCAD	6/25/96	PJH	RCW
B	ADDED NOTES; B ₁ ADDED VIEW; ITEM 7 WAS 91151A033	6/21/06	RWN	MRS

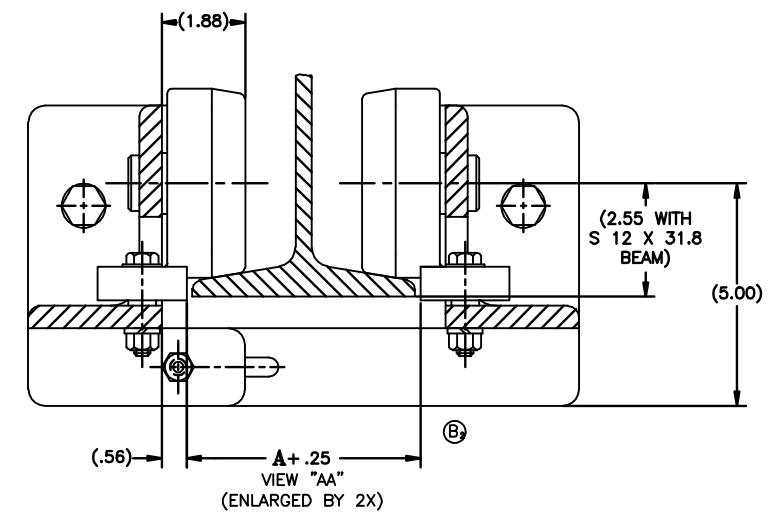
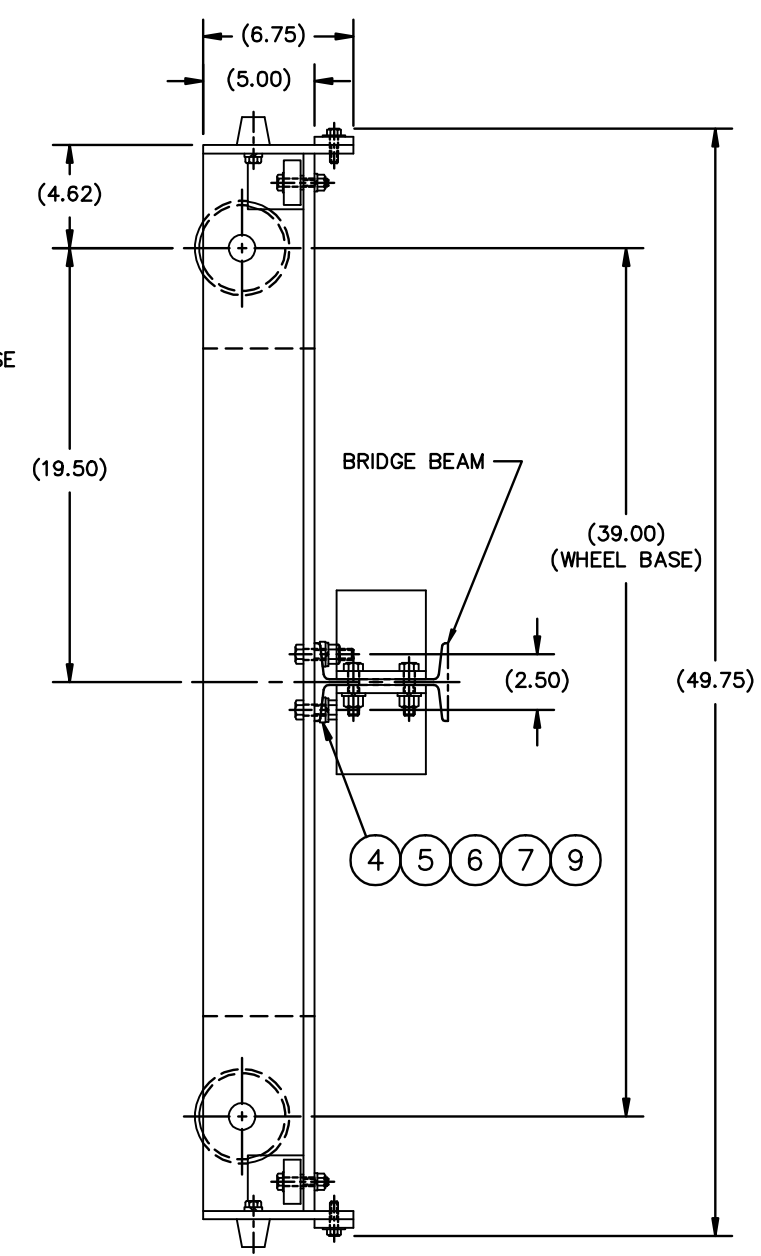
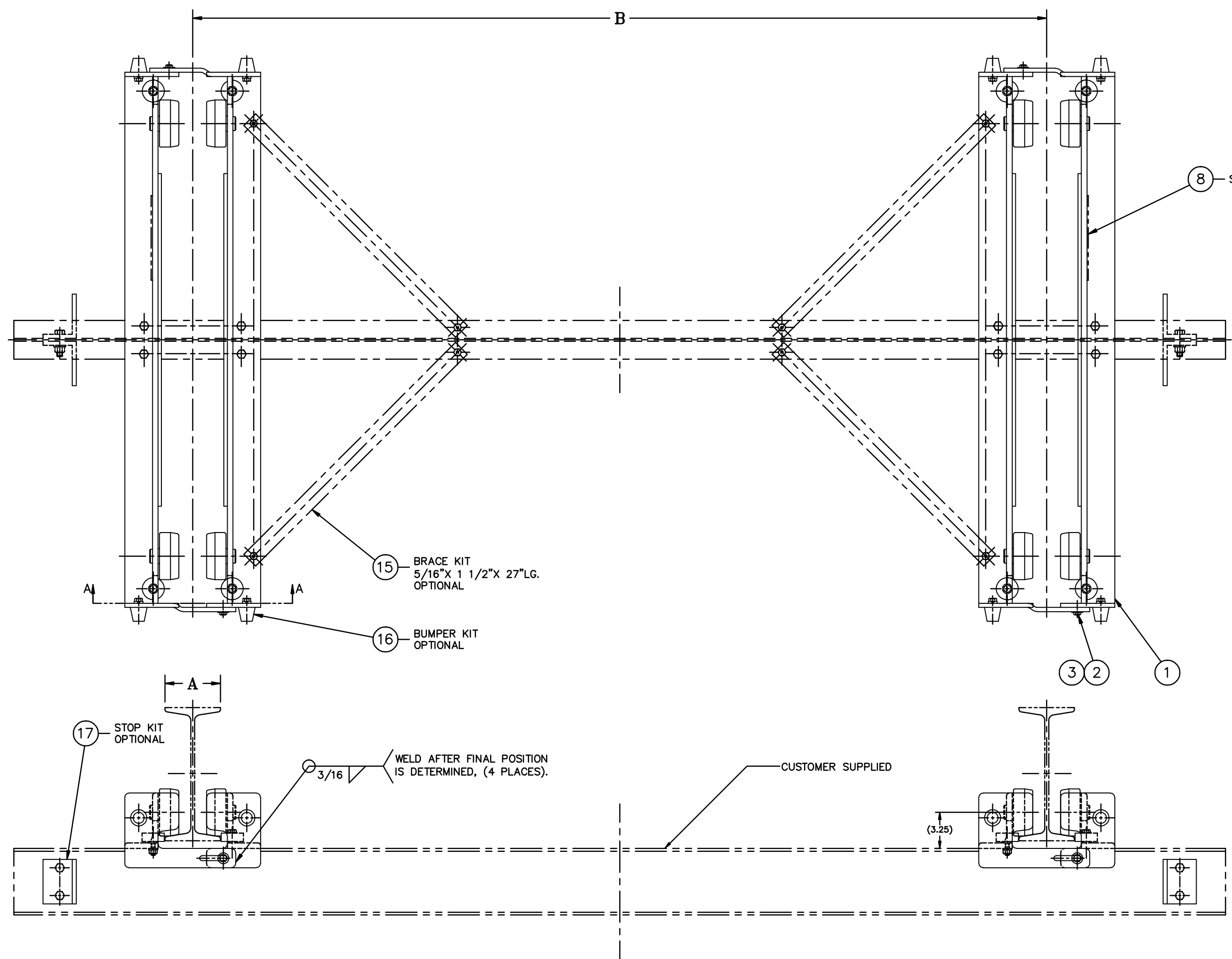

SEE NOTE #2

47901	2	6,000 POUND DECAL	(3 TON)
44714	2	4,000 POUND DECAL	(2 TON)
44713	2	3,000 POUND DECAL	(1 1/2 TON)
44712	2	2,000 POUND DECAL	(1 TON)
44711	2	1,000 POUND DECAL	(1/2 TON)
44710	2	500 POUND DECAL	(1/4 TON)

- NOTES:
- TWO COATS OF FAST DRYING SAFETY YELLOW COLOR NO. 13538 OR 1310.
 - CUSTOMER TO SPECIFY CAPACITY DECAL.
 - SUPPLIED IN HARDWARE KIT B-02-054477.
 - BRIDGE CRANES CAN ALSO BE RUN ON W-BEAM SHAPES.

		BEAM CHART (S-BEAMS)									
B SPAN		10.0'	12.5'	15.0'	17.5'	20.0'	22.5'	25.0'	27.5'	30.0'	
LOAD	500#	6 I X 12.5#	6 I X 12.5#	6 I X 12.5#	6 I X 12.5#	6 I X 12.5#	6 I X 12.5#	7 I X 15.3#	7 I X 15.3#	7 I X 20.0#	
	1000#	6 I X 12.5#	7 I X 15.3#	7 I X 15.3#	7 I X 15.3#	7 I X 20.0#	8 I X 18.4#	8 I X 23.0#	10 I X 25.4#	10 I X 25.4#	
	2000#	7 I X 15.3#	8 I X 18.4#	8 I X 23.0#	10 I X 25.4#	10 I X 25.4#	10 I X 35.0#	12 I X 31.8#	12 I X 31.8#	12 I X 35.0#	
	3000#	8 I X 23.0#	10 I X 25.4#	10 I X 35.0#	12 I X 31.8#	12 I X 35.0#	15 I X 42.9#	15 I X 42.9#	15 I X 42.9#	15 I X 42.9#	5.25 S 12.0 X 40.8
	4000#	10 I X 25.4#	10 I X 35.0#	12 I X 31.8#	15 I X 42.9#	15 I X 42.9#	15 I X 42.9#	15 I X 42.9#	18 I X 54.7#	18 I X 54.7#	5.00 S 12.0 X 31.8
	6000#	12 I X 31.8#	12 I X 31.8#	12 I X 31.8#	15 I X 42.9#	15 I X 42.9#	15 I X 42.9#	18 I X 54.7#	18 I X 54.7#	18 I X 54.7#	3.33 S 6.0 X 12.5

17	40840	1	SAFETY STOP KIT	OPTIONAL
16	44601	1	BUMPER KIT	OPTIONAL
15	44596	1	BRACE KIT	OPTIONAL

9	6620-11	8	FLAT WASHER	.546 X 1.203 X #11GA. THK.
8	47949	8	NAMEPLATE	
7	GG 1/2 BEVEL	8	BEVEL WASHER	1/2 BOLT SIZE McMASTER-CARR OR EQ.
6	COML	8	HEX. HD. SCREW	1/2-13 X 2-1/4 GRADE #5 OR #6
5	COML	8	LOCK WASHER	1/2 MED.
4	COML	8	HEX. NUT	1/2-13
3	COML	4	HEX. HD. SCREW	3/8-16 X 1-1/4 GRADE #5
2	COML	4	FLAT WASHER	3/8
1	47906	4	SIDE ANGLE ASSEMBLY	

ITEM #	PART NUMBER	QTY	DESCRIPTION	MATERIAL OR NOTE	SPECIFICATION
SEE DETAILS					
DRAWN BY: DJH		CHECKED BY: PJH		GEOMETRY CREATED IN: AutoCAD	
DATE DRAWN: 1/6/94		CUSTOMER:		BRIDGE CRANE ASSEMBLY (WITH GUIDE WHEEL)	
DIMENSIONS ARE IN INCHES UNLESS OTHERWISE SPECIFIED		TOLERANCES UNLESS OTHERWISE SPECIFIED		CODE IDENT NO. 52793	
MACHINING & STAMPING OPERATIONS		WELDMENTS & SHEET METAL FABRICATIONS		PART NUMBER / FILE NAME: 47905	
FRACTION 2/16 DECIMALS .125 ANGULAR 25°		FRACTION 3/8 DECIMALS .375 ANGULAR 31°		SCALE: 1/4"	
DO NOT SCALE DRAWING		REFERENCE: 48498, 44600, 46758, 44525		SHEET: 1 of 1 CHARTED	

WEIGHT: 300 LBS